

GearBoss® Team Cart™

GearBoss is an equipment storage and transportation solution designed to transform your equipment room into a point of pride. GearBoss is a high-density storage solution that uses an innovative system of tracks and rolling carts and accessories to reduce the square footage of your storage area by at least half. GearBoss units are designed to encourage airflow and improve sanitation and odor issues. The modular system features accessories specific for the needs of bulky equipment like helmets and shoulder pads. Accessories like panels and doors can be added for security, and in matching school colors they present an unmistakable message of program pride. All Team Carts have a ten-year warranty.

Intended Use

- The GearBoss Team Cart is intended for use on the track but can also leave the track for transport-to-the-event-location; This moves equipment closer to where it's being used and can be secured to create temporary storage around your facility
- The GearBoss Team Cart is intended for indoor use in normal ambient temperature and humidity conditions; Components must not be exposed to prolong outside weather conditions
- Roller guides follow the track and can be recessed into clip holder when the cart is being used for transport
- The heavy-duty commercial-grade swivel casters are intended for easy moving on hard surfaces such as concrete, gym floors, tile and low pile unpadded carpet

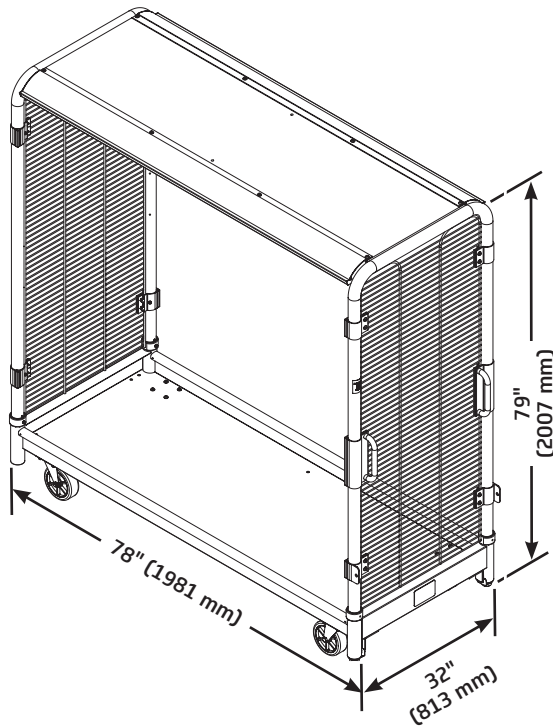

32" Team Cart

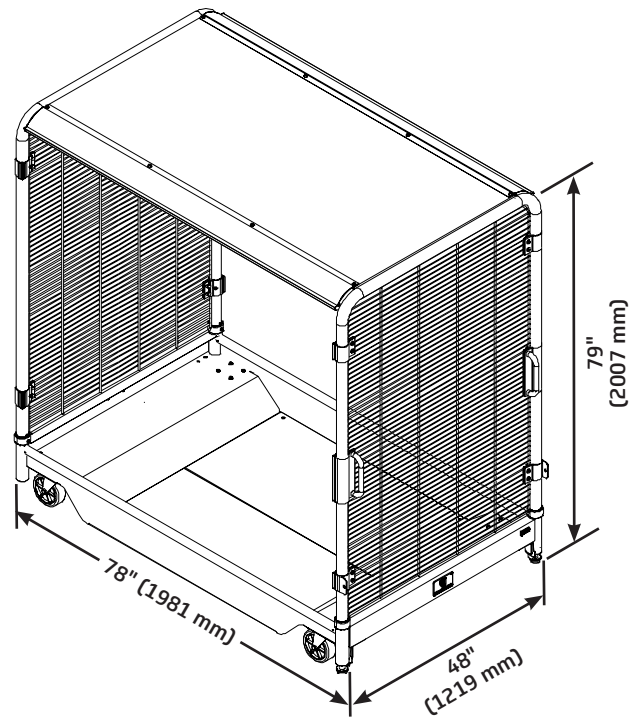

48" Team Cart

Specifications

- Welded chassis made from 16-gauge, 14-gauge and 12-gauge components
- Upright support tubes constructed from large 2" (51 mm) diameter, 16-gauge steel tubing
- Resistant welded heavy-duty steel wire grille end frames
- Durable powder-coat paint finishes
- Various colors available for wire grille ends
- Heavy-duty 6" swivel casters with polyurethane non-marring outer
- Aluminum Rail extrusion holds carts in place and guides them as they are moved; 8' (2438 mm) sections affix to floor with anchor bolts
- Roller guides made of glass-filled nylon follow the track keeping the cart aligned in the system
- Roof panel constructed from solid 5/8" thermofused composite wood core with aluminum extrusions
- Roof assembly and wire shelf load capacity is 150 lb (68 kg) each evenly distributed; Total cart load capacity is 400 lb (181 kg)
- UL GREENGUARD certified - product certified for low chemical emissions: www.ul.com/gg - UL 2818
- Shipped ready-to-assemble with detailed instructions, assembly takes approximately 60 minutes with two people per cart; Wenger assembly and installation is optional
- 32" Team Cart dimensions: 78"w x 79"h x 32"d (1981 x 2007 x 813 mm)
- 48" Team Cart dimensions: 78"w x 79"h x 48"d (1981 x 2007 x 1219 mm)
- Approximate weight: 32" (813 mm) Team Cart, 250 lb (113.4 kg); 48" (1219 mm) Team Cart, 335 lb (151.9 kg)
- Product numbers: 32" (813 mm) Team Cart 240B802; 48" (1219 mm) Team Cart 240A805
- Patent pending

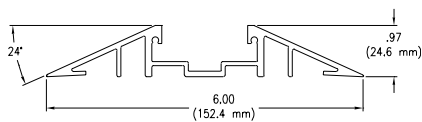

Aluminum Rail Extrusion

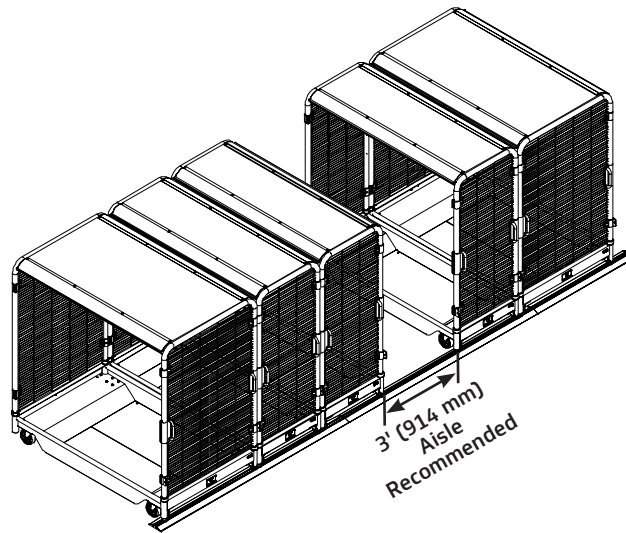

Wenger

JRCLANCY

GEARBOSS

© 2024 Wenger Corporation
USA/2024-03

Minnesota Location

Wenger Phone 800.4WENGER (493-6437) Wenger Worldwide +1.507.455.4100 | Parts & Service 800.887.7145 | wengercorp.com
GearBoss Phone 800.493.6437 | gearboss.com
555 Park Drive, PO Box 448 | Owatonna | MN 55060

New York Location

J.R. Clancy Phone 800.836.1885 JR Clancy Worldwide +1.315.451.3440 | jrclancy.com | 7041 Interstate Island Road | Syracuse | NY 13209